

# MODEL SSG



Revolving Racks: (15) 12" x 42"  
Cooking Surface: 52.5 Sq. Ft.

\*Shown with cook and hold option

**OLE HICKORY  
PITS™**

WOOD BURNING BARBECUE PITS



**1-800-223-9667**

333 North Main Street ~ Cape Girardeau, MO ~ 63701

Email: [main@olehickorypits.com](mailto:main@olehickorypits.com)

[www.olehickorypits.com](http://www.olehickorypits.com)

# MODEL SSG

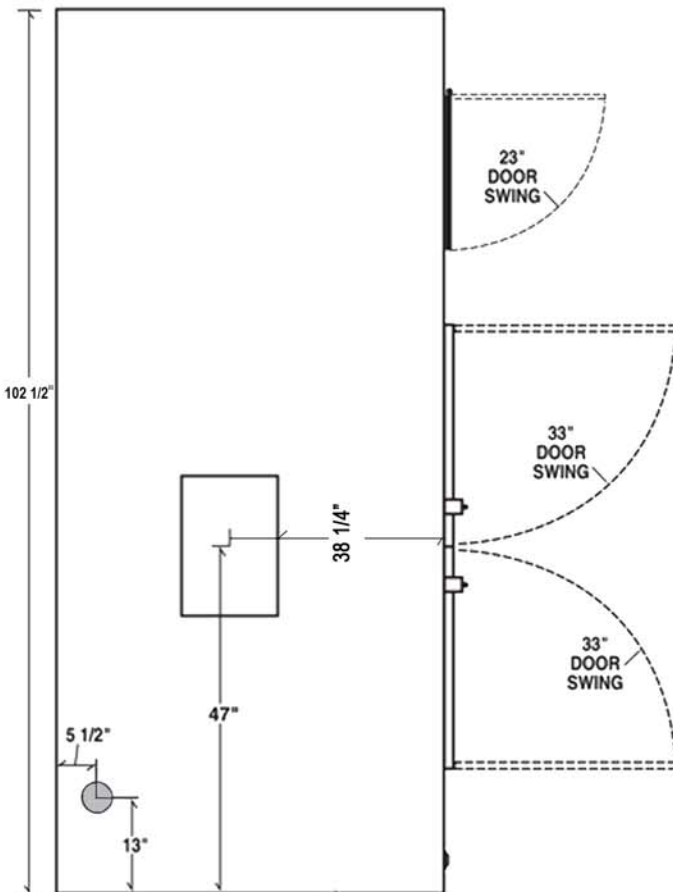
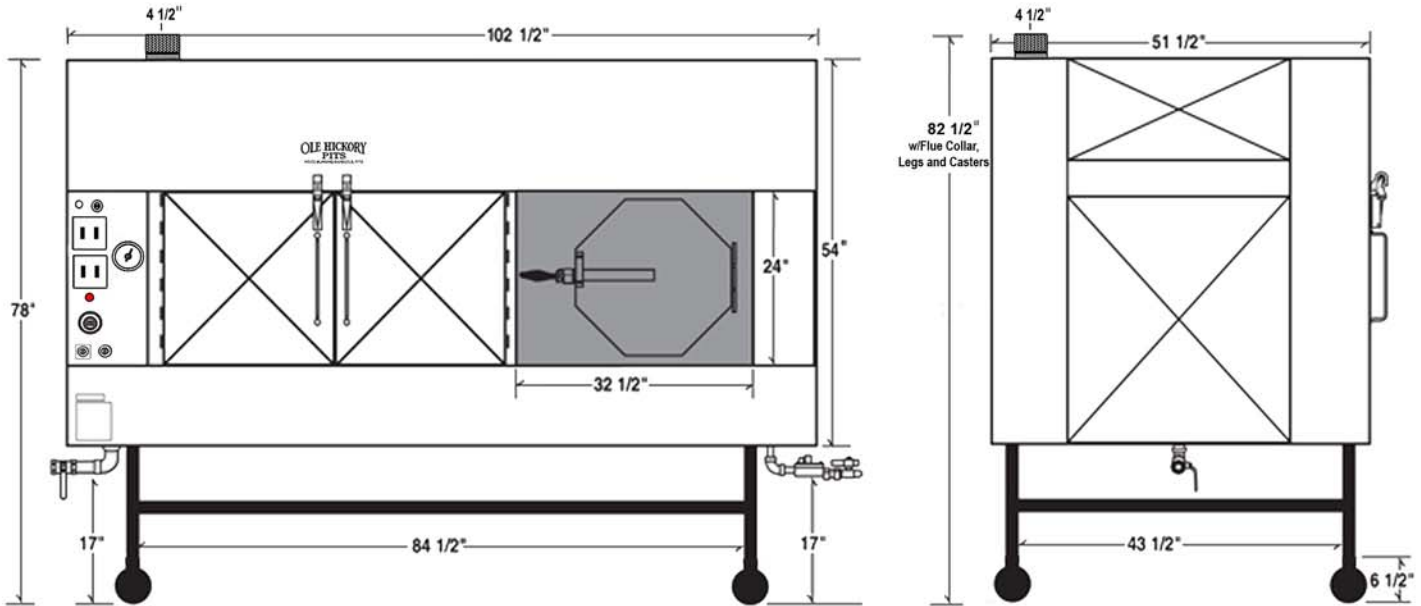

**Construction:** Heavy duty 12 gauge steel interior side walls (100% welded & inspected seams) tubular steel frame, 22 gauge stainless steel exterior, mineral wool insulation – rated 1200 degrees F. (contains no asbestos or fiberglass)

**Electrical:** 110 volts, 60 HZ, single phase, 15 amp – AVOID NON-GROUNDED EXTENSION CORDS.

**Gas Burner:** One (1) 65,000 BTU burner with electronic ignition. Available for LPG (Propane) or natural gas.

**Firebox:** Two (2) regular fireplace size logs will last for up to 6 hours of cooking. Air over firebox circulation.

**Temperature range:** Thermostat control range 100 degrees F. to 325 degrees F.

**Upper Limit Control Switch:** Extra safety feature (set at 350 degrees F).

**Dial Thermometer:** 2 1/2" diameter.

**Heavy Duty Foot Switch:** Rotisserie advance.

**Casters:** Four (4) Heavy duty, ETL approved.

**Convecture™ System:** One (1) 1/4 HP motor with 10" fan blade provides a mix of both heat and smoke for product consistency.

**Flue:** 4" Diameter.

**Grease Drain:** 2" Pipe with 2" Ball Valve.

**Weight:** 2100 lbs, uncrated.

**Rotisserie:** 15 Racks, 12" X 42", 52.5 Sq. Ft. total cooking surface. Nickel-chrome (stainless available at extra cost) removable for easy cleaning.

**Rotisserie Drive:** Heavy duty 1/4 HP motor – long lasting chain drive system utilizing gear reduction.

**Optional Equipment:** Cook and Hold, Competition Switch and other options available.



**Ole Hickory Pits ~ 1-800-223-9667 ~ (573) 334-3377 ~ [www.olehickorypits.com](http://www.olehickorypits.com)**